

1 GeV リニアック検討資料

1 GeV LINAC DESIGN NOTE

題目 (TITLE) NEW DESIGN OF AN RF BEAM CHOPPER

著者 (AUTHOR) T. Kato

概要 (ABSTRACT)

A 432-MHz rf beam chopper for the JHP (Japanese Hadron Project) proton linac was designed to enable a decrease in beam losses after injection into a circular accelerator. A new-type deflecting cavity was modeled using a code called MAFIA. Two model cavities were then fabricated and measured. To increase the efficiency of the chopper system, a fast filling time of the rf field in the cavity is important; this can be achieved with a low loaded Q-value of the cavity. A loaded Q-value of 14 for the model cavity has been obtained, corresponding to a filling time of 12 nsec. There are presently plans to install the chopper system between an RFQ (radio frequency quadrupole) cavity and a DTL (drift tube linac).

KEY WORDS:

Ion source, RFQ, DTL, CCL, Magnet, Monitor, Beam Dynamics, Transport, Vacuum, Cooling
Klystron, Low level rf, High power rf, Modulator
Control, Operation, Radiation, Others

NEW DESIGN OF AN RF BEAM CHOPPER

T. Kato

National Laboratory for High Energy Physics
Oho, Tsukuba-shi, Ibaraki-ken, 305, Japan

Abstract

A 432-MHz rf beam chopper for the JHP (Japanese Hadron Project) proton linac was designed to enable a decrease in beam losses after injection into a circular accelerator. A new-type deflecting cavity was modeled using a code called MAFIA. Two model cavities were then fabricated and measured. To increase the efficiency of the chopper system, a fast filling time of the rf field in the cavity is important; this can be achieved with a low loaded Q-value of the cavity. A loaded Q-value of 14 for the model cavity has been obtained, corresponding to a filling time of 12 nsec. There are presently plans to install the chopper system between an RFQ (radio frequency quadrupole) cavity and a DTL (drift tube linac).

Introduction

Figure 1 shows the required pulse structure of the linac beam for the Japanese Hadron Project (JHP).¹ The required rf pulse length for the chopper is 130 nsec with a 3-MHz repetition rate. The linac for the JHP comprises a 432-MHz RFQ (3 MeV), a 432-MHz DTL (150 MeV) and a 1296-MHz high- β linac (1 GeV). Thus, there are two ways of installing a chopper system: before or after acceleration by the RFQ. A traveling-wave beam chopper² developed at LANL can be applied for both cases. In the former case, the space-charge effects are dominant in the energy range below 50 keV. In the latter case, a long structure and a high voltage are necessary since the beam energy is 3 MeV. Therefore, it requires some device to chop and focus the beam simultaneously in order to be consistent with the beam optics between an RFQ and a DTL. Here, we describe an rf chopper system, which is simple and divided into many short sections, if necessary, and will be installed between an RFQ and a DTL. A rather long beam line between the RFQ and the DTL is assumed in order to obtain both transverse and longitudinal matching of the

beam. It consists of a 2-m long drift space, a bunching cavity and a 1.4 m drift space. Some transverse focusing elements should also be arranged along the beam line, since there is sufficient room to install several chopper cavities and focusing elements alternately.

Cavity design

A 432-MHz rf dipole cavity (RFD) is an attractive candidate for producing a deflecting electric field. An RFD consists of two vanes and an outer wall. Figure 2 shows an RFD cavity shape. Code MAFIA³ can be used to calculate the rf properties for a three-dimensional geometry. The cavity is excited with a TE₁₁-like mode. A cavity length of 10 cm is sufficiently short to install these cavities and focusing Q-magnets alternately. The width of the vane is 27 mm, which corresponds to a phase width of 180 degrees for a 3-MeV beam. Two pipes of 14 mm in diameter are inserted from both end plates of the cavity in order to shield the beam from rf magnetic fields. Two specific features of the cavity are the concentration of an electric field in the center part of the vanes and ease of

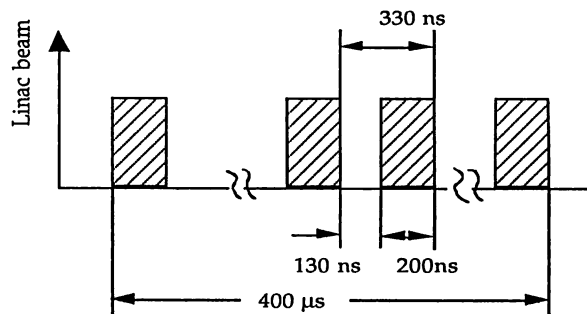

Fig.1 Required pulse structure for JHP linac beam.

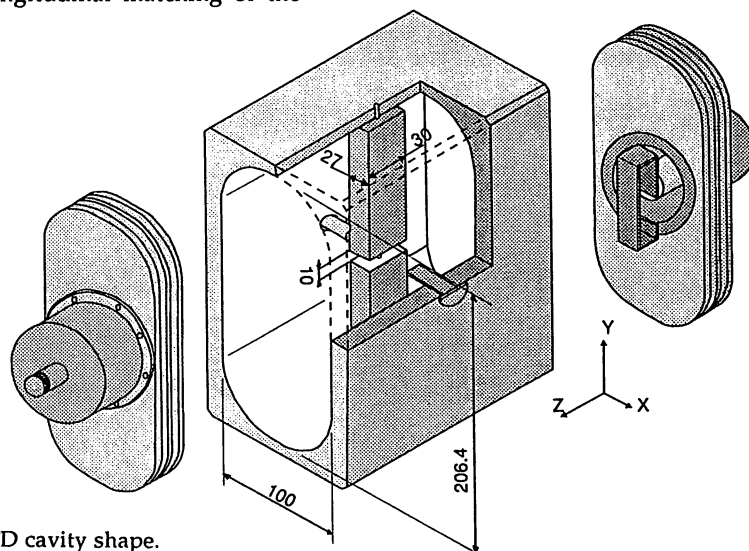

Fig.2 RFD cavity shape.

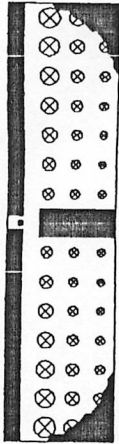

Fig. 3 Distribution of the magnetic field.

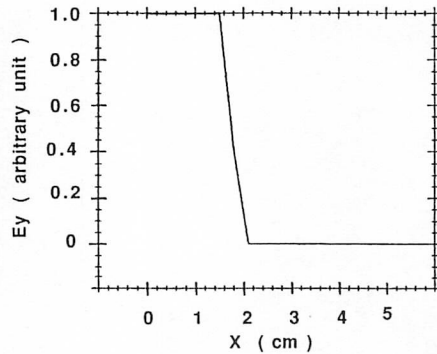
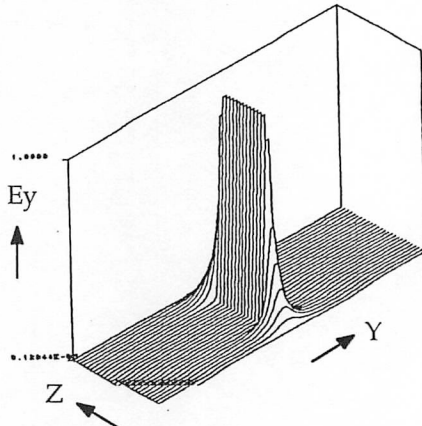

Fig. 4 Distribution of the deflecting electric field.



obtaining a low loaded Q-value using two large coupling loops through the wide side plates. Calculated rf properties are shown in Figs. 3 and 4. From the calculation results we assume that the deflecting field is spatially uniform along the beam axis.

Rf properties

In order to provide a 10-mrad deflection for the beam, it is necessary to achieve an electric field of 3.4 MV/m with a 27-mm gap length, where the power consumption is about 26 kW and the unloaded and loaded Q-values are 10200 and 20, respectively. Since the deflecting angle is proportional to the amplitude of the electric field, it is advantageous to use several cavities to decrease the required rf peak power. If a series of N cavities is used, the required peak electric field is reduced to 1/N; then, the rf peak power is reduced to 1/N² for each cavity.

Table 1

Rf power relations for two-ports cavity.

$$P_{cav} = \frac{4\beta_1}{(1+\beta_1+\beta_2)^2} P_{in}$$

$$P_{ref} = \frac{(1-\beta_1+\beta_2)^2}{(1+\beta_1+\beta_2)^2} P_{in} \quad Q_L = \frac{Q_0}{1+\beta_1+\beta_2}$$

$$P_{tr} = \frac{4\beta_1\beta_2}{(1+\beta_1+\beta_2)^2} P_{in} \quad \tau = \frac{2Q_L}{\omega_0}$$

The basic power relations for a two-port cavity are listed in Table 1, where P_{cav} , P_{in} , P_{ref} and P_{tr} represent the rf power in a cavity, the incident power, the reflected power and the transmitted power, respectively. Q_0 , Q_L , β_1 and β_2 represent the unloaded and loaded Q-values and coupling coefficients of two rf ports. We assume that β_1 is equal to β_2 for simplicity. If β_1 and β_2 are much larger than 1 (denoted by β) we have $P_{cav} = P_{in} / \beta$.

As can be seen in Table 1, it is necessary to reduce the loaded Q-value by increasing the coupling coefficients so as to achieve a fast filling time (τ) of the cavity. Then, the required rf power is increased by a factor of β compared with that of a matched rf port cavity. Almost all incident power can be transmitted through the cavity with little reflected power.

There are fast rf switches with rise times less than 5 nsec. It is therefore easy to obtain an rf pulse with a fast rise time in the low rf power level. However, when the rf pulse is amplified, an rf power amplifier with extreme characteristics is required, depending on the required rise time. A power amplifier with a broad band width and a few kW output power becomes possible since the technique of rf power amplifier of a solid-state type has made progress during the last decade. Therefore, the number of RFD cavities used in the chopper system should be determined by several factors, such as the spatial limitation of the beam line, the technical difficulty of a high power amplifier and cost optimization of a total chopper system including cavities, rf amplifiers and control systems. It should be also noted the slower filling time causes a transverse emittance growth during the filling time, resulting in extra beam losses in the high-energy part of the linac and the following circular accelerator. The RFD parameters for several choices regarding the number of cavities are summarized in Table 2.

Table 2

Typical parameters for the rf chopper system.

Number of cavities	E _{peak} MV/m	P _c /cavity kW	Total power kW
1	3.39	26.2	26.2
2	1.70	6.5	13.1
3	1.13	2.9	8.7
4	0.85	1.6	6.5
5	0.68	1.0	5.2
6	0.57	0.73	4.4

The figures in Table 2 are the results of calculations based on the assumption that a standard particle (assumed at the

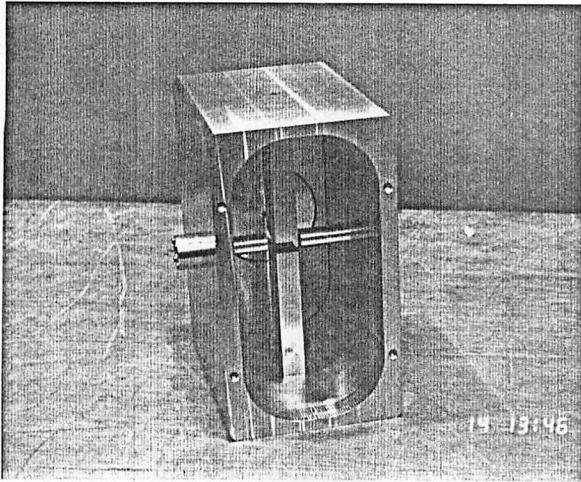

Fig. 5 Photograph of RFD model cavity.

longitudinal center of the bunch) is deflected by 10 mrad by all cavities. The effect of the longitudinal spread of the bunch is simply considered as decreasing the deflecting electric field by a factor of $\cos \phi$, where ϕ denotes the half width of the bunch in terms of the rf phase. Then, the required rf power increases by a factor of $1/(\cos \phi)^2$. The effects of the transverse emittance of the beam should also be taken into account. The calculation of beam dynamics for an RFQ output beam of $1.3 \pi \text{ mm.mrad}$ normalized emittance shows that either two RFD cavities (each with a 6-mrad deflection) or four RFD cavities (each with a 4-mrad deflection) is required in order to distinguish a deflected beam from a non-deflected one in transverse phase space. From the viewpoint of the longitudinal spread of the beam, an option of a small number of cavities has an advantage, in that the multiplication factors of the required rf power due to the phase spread are 1.17 for a two-cavity-system and 1.7 for a four-cavity system. Preliminary results of the required rf power based on the beam dynamics calculation, including the effects of both longitudinal and transverse emittances, are shown in Table 3.

Table 3

Required rf parameters for the chopper system.

Number of cavities	Deflection mrad	Pc/cavity kW	Total power kW
1	14	58.2	58.2
2	6	11.0	22.1
4	4	7.1	28.5

Experimental results with model cavities

Two RFD cavities, one is made of aluminum and the other of steel, were fabricated(Fig.5). The measured unloaded and loaded Q-values, as well as corresponding filling times, are shown in Table 4.

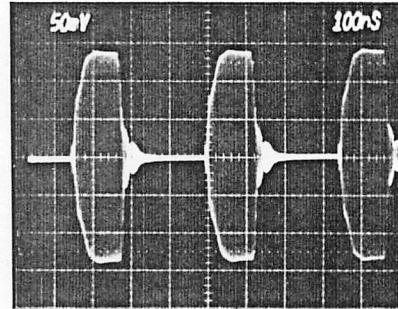

Fig.6 Transmitted amplitude at a low power level with a loaded Q-value of 18. (100 ns/div)

Table 4

Measured Q-values of the RFD cavities.

	CAVITY-1	CAVITY-2
MATERIAL	Al	Fe
Q_0	4400	290
Q_L	16	14
τ (nsec)	13	12

The loaded Q-values could easily be changed by varying the sizes of the input and output loop couplers. The minimum loaded Q-values obtained are listed in Table 4. Generally speaking, mixing of the near-by-mode is one of the major problems under low Q-value operation. In this case, the frequency of the near-by-mode can be tuned to 700MHz, which is sufficiently far from the fundamental frequency.

The transmitted rf power through the two-port cavity during an rf pulse can be written as

$$P_r = \left[1 - \exp(-\omega t / 2Q_L) \right]^2 P_i$$

The measured rf amplitude at a low power level with a loaded Q-value of 18 is shown in Fig.6.

From the results described above, we may conclude that the fundamental rf properties of the RFD cavity are satisfactory and the key to success in practical application depends on a development of a high-power amplifier with a fast rise time.

Acknowledgement

The author would thank to Mr. C. Kubota regarding the mechanical design of the cavity.

References

1. M. Kihara, Proc. Advanced Hadron Facility Accelerator Design Workshop, Los Alamos, p.4 (1988).
2. R. F. Bentley, J. S. Lunsford and G. P. Lawrence, IEEE Trans. Nucl. Sci. Vol. NS-22, 1526 (1975).
3. T. Weiland, Part. Accel. 17, 227(1985).